



 United Technologies

INSTALLATION OPERATION AND MAINTENANCE INSTRUCTIONS



Air-cooled condensing units with axial
fan and free vertical discharge

38ZS/ZF

Nominal cooling capacity 20 - 135 kW
Nominal heating capacity 20 - 145 kW
50 Hz

CONTENTS

1 - INTRODUCTION	5
2 - SAFETY ADVISE	5
3 - OPERATION LIMITS	6
4 - UNIT IDENTIFICATION	6
5 - TRANSPORT AND HANDLING	6
5.1 Transport	6
5.2 Discharging of the unit.....	6
5.3 Centre of gravity coordinates.....	7
6 - POSITIONING AND INSTALLATION	8
6.1 Choice of location.....	8
6.2 Anchorage for silent-blocks	8
6.3 Recommended service clearance for commissioning and maintenance operations (mm)	9
6.4 Sound level.....	9
7 - CHECKING BEFORE COMMISSIONING	10
7.1 Electrical connection	10
7.2 Cooling connections.....	13
7.3 Condensate drain connection	14
7.4 Checks in the axial fans	14
8 - SAFETY ELEMENTS	15
9 - COMMISSIONING	16
9.1 Checks prior to commissioning.....	16
9.2. Possible problems at commissioning.....	17
9.3. Operational checks.....	17
10 - MAINTENANCE	18
10.1 General recommendations	18
10.2 Servicing	19
10.3 Access to the main components	19
11 - CONTROL AND ANALYSIS OF BREAKDOWNS	21
12 - FINAL SHUTDOWN	22
12.1 Shutting down	22
12.2 Recommendations for disassembly	22
12.3 Fluids to be recovered for treatment.....	22
12.4 Materials to be recovered for recycling.....	22
12.5 Waste electrical and electronic equipment (WEEE)	22

1 - INTRODUCTION

The **38ZS/ZF range** are air-cooled condensing units designed for installation outdoors. They can be connected on-site with one direct expansion exchanger (or two in case of models 200 to 360).

• **1 cooling circuit, 1 compressor:**

Models: 90 / 100 / 120 / 160 / 180 / 182

• **2 cooling circuits, 2 compressors:**

Models: 200 / 240 / 320 / 360 / 420 / 485 / 540 / 600

Two options are available:

- **38ZS series: non reversible** units.
- **38ZF series: reversible** units

They are equipped axial fan(s) with free vertical discharge, hermetic scroll-type compressor(s) and electric panel with electronic control with optimized components for the refrigerant R-410A.

A vast number of options meet numerous operating demands.

All of the units are tested and checked in the factory.

The units comply with European Directives:

- Machinery Directive 2006/42/EC (MD)
- Electromagnetic Compatibility Directive 2014/30/EU (EMC)
- Low Voltage Directive 2014/35/EU (LVD)
- Pressure Equipment Directive 2014/68/EU (Category 2) (PED)
- RoHS Directive 2011/65/EU (RoHS)
- Eco-design Directive 2009/125/EC (ECO-DESIGN)
- Energy Labelling Directive 2017/1369/EU (ECO-LABELLING)
- Harmonised Standard: EN 378-2:2012 (Refrigerating systems and heat pumps - Safety and environmental requirements).

Technicians who install, commission, operate and service the unit must possess the necessary training and certifications, understand the instructions given in this manual and be familiar with the specific technical characteristics of the installation site.

2 - SAFETY ADVISE

To avoid any risk of accident during installation, commissioning or maintenance, it is obligatory to take into consideration the following specifications for the units: refrigerated circuits under pressure, refrigerant presence, electrical voltage presence and implantation place.

Because of all of this, only qualified and experienced personnel can perform maintenance tasks or unit repairs.



It is required to follow the recommendations and instructions in this brochure, the labels, and the specific instructions.

Compliance with the norms and regulations in effect is mandatory. It is recommended to consult the competent authorities regarding the applicable regulations for users of units or components under pressure. The characteristics of these units or components are included on the plates of characteristics or in the regulatory documentation provided with the product.



Caution: Before intervening in the unit, verify that the main power to the unit is cut off. An electric shock can cause personal damage. The main disconnect switch is located in the unit's electric cabinet.



The compressor and line surfaces can reach temperatures above 100°C causing burns to the body. In the same fashion, under certain conditions these surfaces can reach very cold temperatures that can cause freezing risks.



During any handling, maintenance or service operations, the technicians involved must be equipped with safety gloves, glasses, shoes, insulating clothing, etc

Refrigerant

Important: These units contain **R-410A**, a fluorinated greenhouse gas covered by the Kyoto protocol.

All interventions on the refrigerating circuit must be performed in accordance with applicable legislation. Within the European Union, it is necessary to observe regulation (EU) No.517/2014,

known as F-Gas, over **Certain greenhouse effect fluoride gases.**

Components of the R-410A	R-32	R-125
Chemical formula	CH2F2	CHF2CF3
Weight ratio	50%	50%
Unitary global warming potential (GWP)	675	3.500
Global warming potential (GWP)	2.088	

Ensure that refrigerant is never released to the atmosphere when the equipment is installed, maintained or sent for disposal.

It is prohibited to deliberately release refrigerant into the atmosphere. The operator must ensure that any refrigerant recovered is recycled, regenerated or destroyed.

The operator is bound by the obligation to perform periodical sealing tests on the refrigerating circuit according to the regulation (EU) No.517/2014. Please, consult the frequency of tests in chapter of "Maintenance".

In case of a leak:

- Toxicity: According to EN 378-1, R-410A belongs to the A1/A1 group, i.e. with high safety both in the mix and also in the case of a leak.
- Although it is not toxic, in case of a leak to atmospheric pressure the liquid phase evaporates. The resulting vapours are still hazardous because they are heavier than air and can force the latter out of the machine rooms. If refrigerant is accidentally released, ventilate the room with fans.
- Although it is not flammable, keep them away from open flames (e.g. cigarettes) as temperatures of over 300°C cause their vapours to break down and form phosgene, hydrogen fluoride, hydrogen chloride and other toxic compounds. These compounds may produce severe physiological consequences if accidentally inhaled or swallowed.
- To detect leaks, an electronic leak detector, an ultraviolet lamp or soapy water must be used. Flame detectors do not help.
- Immediately repair any refrigerant leak, using a recovery unit specific for R-410A that avoids a possible mixture of refrigerants and/or oils.

3 - OPERATION LIMITS

Temperature conditions		Cooling	Heating
Refrigerant ①	Minimum	-6 °C	40 °C
	Maximum	10 °C	52 °C
Inlet air	Minimum	12 °C ②	-10 °C WB
	Maximum	48 °C	15 °C WB

- ① For connection with a direct expansion exchanger.
- ② With control of operation condensation pressure activated up to -10°C.

4 - UNIT IDENTIFICATION

Check the unit for any damage or missing components upon delivery.



Check that the details on the label, the packing and the name plate match the order. If equipment has been damaged, or there is a shortfall in delivery, notify accordingly.

All units bear, legibly and indelibly, a name plate located in a prime space, as appears in the attached image: Check that this plate matches the correct model.

Año/An. Year 1	Ref/Reference 2	No Serie/serial Nbr. 3
Producto/Product/Produit 4		
Ref. Produit/Item Nbr 5	6	7
Tension/Voltage 8	Kit Elec. 9	Max.Intensidad/Intensité/Current 10
Refrigerant 11	Refrig.KG (Fábrica/Factory/Usine)/Co2 Teq. 12	
PSmax(API/HP) 13	PSmax(BP/LP) 14	Temp. Max./ IP 15
Peso/Poids/Weight 16		NoBo 17

CARRIER SCS
 Route de Thil
 01122 Montluel-FRANCE

Fabricante/Fabricant/Manufacturer:
 Compañía Industrial de Aplicaciones Térmicas, S.A.
 P. Ind. Llanos de Jarata s/n. 14550 Montilla-SPAIN

Contient des gaz à effet de serre fluorés \ Contains fluorinated greenhouse gases regulated by the Kyoto protocol
 Contiene gases fluorados de efecto invernadero regulados por el protocolo de Kyoto

Legend

- 1** Year of manufacture
- 2** Commercial product name
- 3** Serial number
- 4** Description of the product
- 5** Purchase order number
- 6** Sales order number
- 7** Work order number
- 8** Power supply
- 9** Power output of the auxiliary electrical heaters kit (optional) (kW)
- 10** Maximum absorbed current under full load (A) (including the electrical kit)
- 11** Type of refrigerant
- 12** Refrigerant content (kg) and Environment impact (CO₂ Teq.)
- 13** Maximum service pressure in the high pressure side (R-410A = 42 bar)
- 14** Maximum service pressure in the low pressure side (R-410A = 24 bar)
- 15** Maximum operating temperature (refer to "Opration limits")
Maximum shipment and storage temperature: +50°C
Electrical protection rating: IP54
- 16** Operation weight (kg) (empty weight + fluid + refrigerant)
- 17** Notified Body number for surveillance of the Pressure Equipment Directive



Important: The serial number must be used in all correspondence regarding the unit.

Markings (name plate, punch marks, labels) must remain visible. They must not be altered, removed or modified.

5 - TRANSPORT AND HANDLING

5.1 Transport

The unit must be handled with care to avoid transport damage. Thus we recommend:

- Do not dispose of the transport supports or the packaging materials until the unit is in its final location.
- For transport in a container, one must be selected that has an easy load and unload to the installation location.

5.2 Discharging of the unit

The unit can be discharged using:

- Forklift truck.
- Crane with a rocker arm and cloth slings.

When using any of the two above methods, it is always mandatory to grasp the unit by the points intended for that purpose, as described in this chapter.

Any handling of the unit by other means or by gripping points different from those described here may be dangerous for both the unit and the personnel who are carrying out the discharging or transport work.



Always check the weight of the set and verify that the discharging method used is approved for handling that weight.

Note: please see the weight and the gravity centre coordinates of each model stated in the following section.

5 - TRANSPORTE Y MANIPULACIÓN

• Discharge via forklift truck:

The unit is designed to be transported safely by using a forklift truck. The forks of the forklift truck must come in on the side of the unit, ensuring that the centre of gravity of the unit remains within the forks, because a misbalance in the transport may cause the unit to turn over and fall from the forklift truck.

The recommended length for the forks will be bigger than the unit width, so that the entire weight-bearing structure can be supported on the forklift truck. This also prevents the possible introduction of the truck's fork into functional parts of the unit that may cause damage to the unit.

The standards and recommendations of the forklift truck must also be respected with regards to the maximum load, inclination of the fork carriage, elevation of the load for transport, and, in particular, the maximum speed.

• Discharge via crane:

A rocker arm, as well as approved cloth slings, both suitable for the dimensions and weight of the unit, must be used in order to carry out the work safely and without causing damage to the units or to workers.

These slings will be hooked or to the two grips screwed on each crossbar.

Make sure that the unit is protected from contact with the hooks to prevent damage to the housing.

The centre of gravity is not necessarily in the middle of the unit and the forces applied to the slings are not always identical. Please consult the weight and the centre of gravity of each model stated in the following paragraph.



The unit must be lifted and fixed with care, with maximum inclination of 15°, since it could harm its operation. Do not raise by points outside of those specified here.

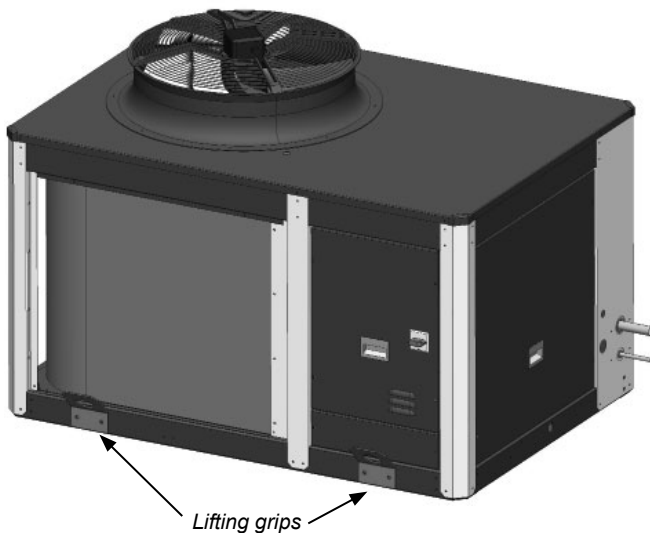

After the placing of the unit, it is recommended to remove the grips, as they can be a hindrance for maintenance. Put the grips back in case of unit transport. Each grip is fixed to the crossbar using two M10 screws.

5.3 Centre of gravity coordinates

Both the weight and the centre of gravity should be consulted before the transport and handling of the unit.

38ZS/ZF	Centre of gravity (mm)			Weight (kg)
	X	Y	Z	
90	945	602	440	275
100	945	602	440	281
120	908	595	589	317
160	913	595	593	326
180	909	584	512	368
182	909	584	512	388
200	1.029	610	658	490
240	1.030	609	657	492
320	1.019	605	777	544
360	1.280	1.110	795	974
420	1.254	1.111	807	1.024
485	1.256	1.108	805	1.029
540	1.278	1.129	780	1.078
600	1.297	1.104	757	1.127

38ZS/ZF - 90 to 320

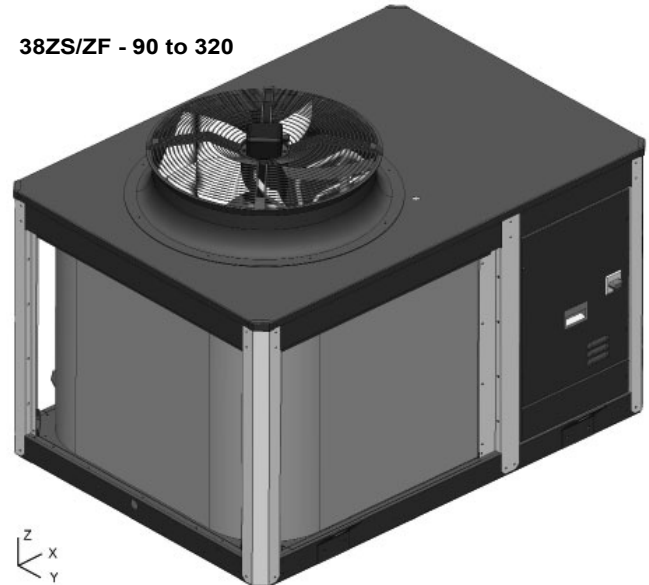

38ZS/ZF - 360 to 600

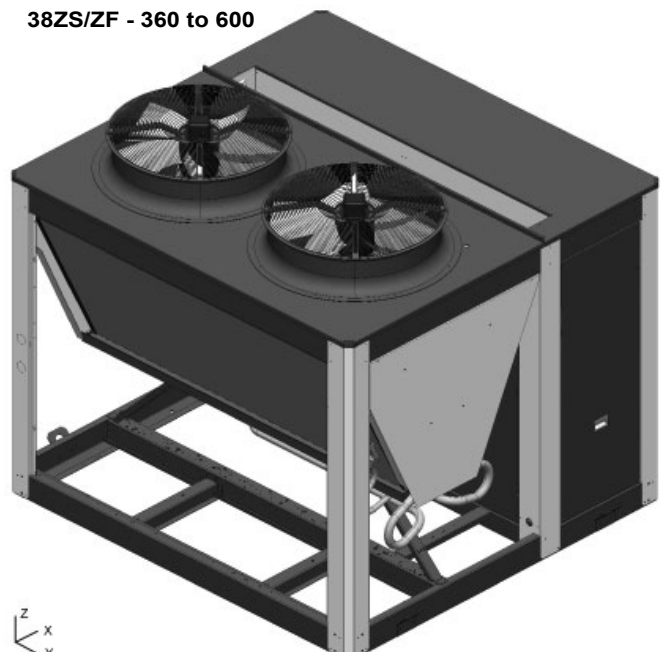

6 - POSITIONING AND INSTALLATION

6.1 Choice of location

When choosing the location, whatever may be the selected fashion, the following precautions have to be taken into consideration:

- It is mandatory to comply with norm EN 378-3 on Safety and Environmental Requirements. Part 3: "In situ" installation and protection to people.
- It is necessary to check that the surface of the floor or the structure supports the weight of the unit (please, consult the weight of the unit in the section "Centre of gravity coordinates").
- The area where the unit will be located must be perfectly accessible for cleaning and maintenance operations (please consult the "Recommended service clearance").
- Leave enough space for air circulation around the unit.
- Since the unit is designed to work outdoors, some specific installation norms must be followed:
 - The unit will be located on the roof of the premises. If it is foreseen that it will work more on heating than on cooling, it is preferable to direct the coil towards the sun. If little work on heating is foreseen, choose North direction.
 - Avoid placing obstacles in the air supply or return. No obstacle may impede the air aspiration into the coils. Do not fix the outdoor coil side in the predominant wind direction.
 - Do not install the unit in a closed enclosure or in conditions that originate air recirculation.
 - The chosen location must not flood and must be above the average height the snow reaches in that region.

Preparation of the ground

- It is necessary to ensure that the surface where the unit is going to be installed is completely flat. Any defect in the preparation of the unit support surface translates into stresses on the structure, which may result in its deformation.
- These units can be installed on the floor or on a brick curb or steel profile.

Based on the fixing solution defined in the installation project, it will be necessary to plan the placement in the base of threaded rods in the expectation that the unit supports can be fixed later on. To do so, it is recommended that a template be made with the heights corresponding to the fixings.



Foresee appropriate damping devices in these fixings to ensure that noise and vibration transmission is avoided (refer to the section "Anchorage for silent-blocks").

Antivibrators assembly (silent-blocks)

- In the event of assembling directly on silent-blocks to the ground, it is recommended that a template of the unit's footprint with the anchoring points of the silent-blocks be made.
- With the help of the crane or the forklift truck, the unit will be raised to a sufficient height that the silent-blocks can be screwed into its base. For their placement in the supports, M10 or M12 (depend on the model) metric threads have been provided.

6.2 Anchorage for silent-blocks

38ZS/ZF -
90 to 320

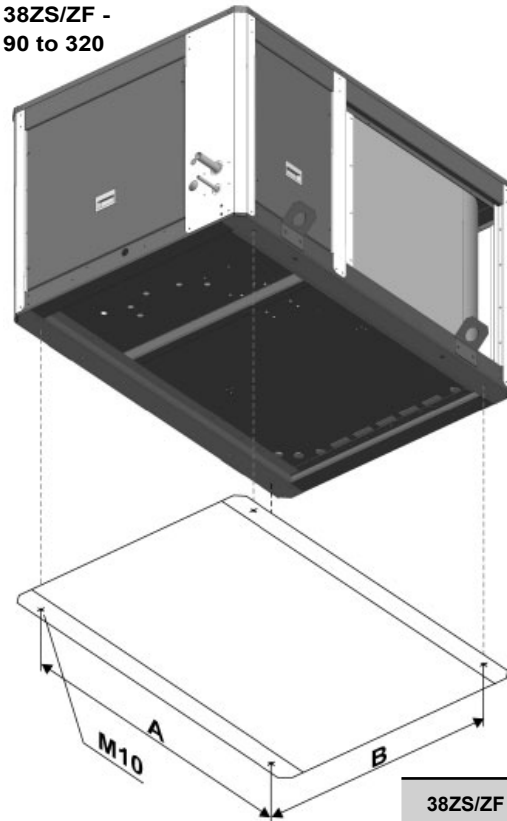

38ZS/ZF	A (mm)	B (mm)
90 to 182	1.257	967
200 to 320	1.557	967

38ZS/ZF -
360 to 600

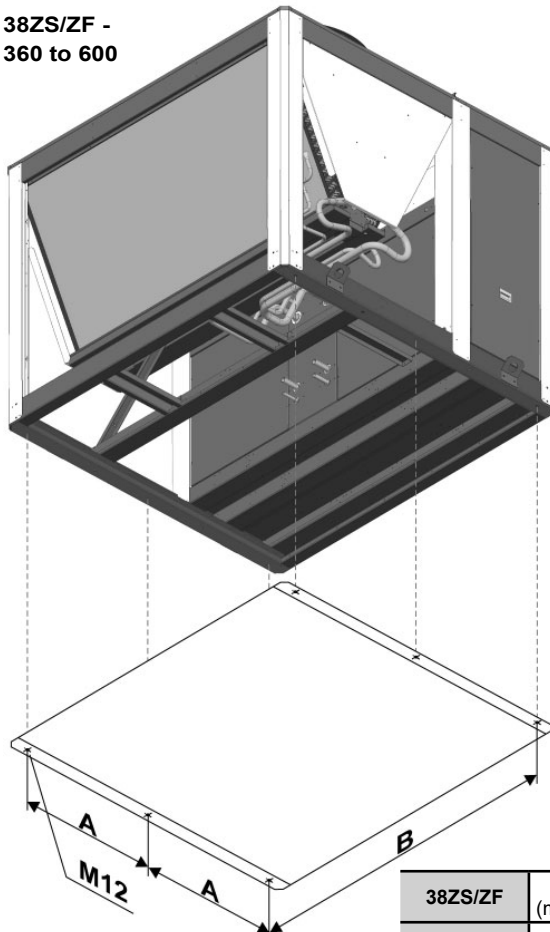

38ZS/ZF	A (mm)	B (mm)
360 to 600	907	2.101

6 - POSITIONING AND INSTALLATION

6.3 Recommended service clearance for commissioning and maintenance operations (mm)



Unit not designed to have overhead obstruction.

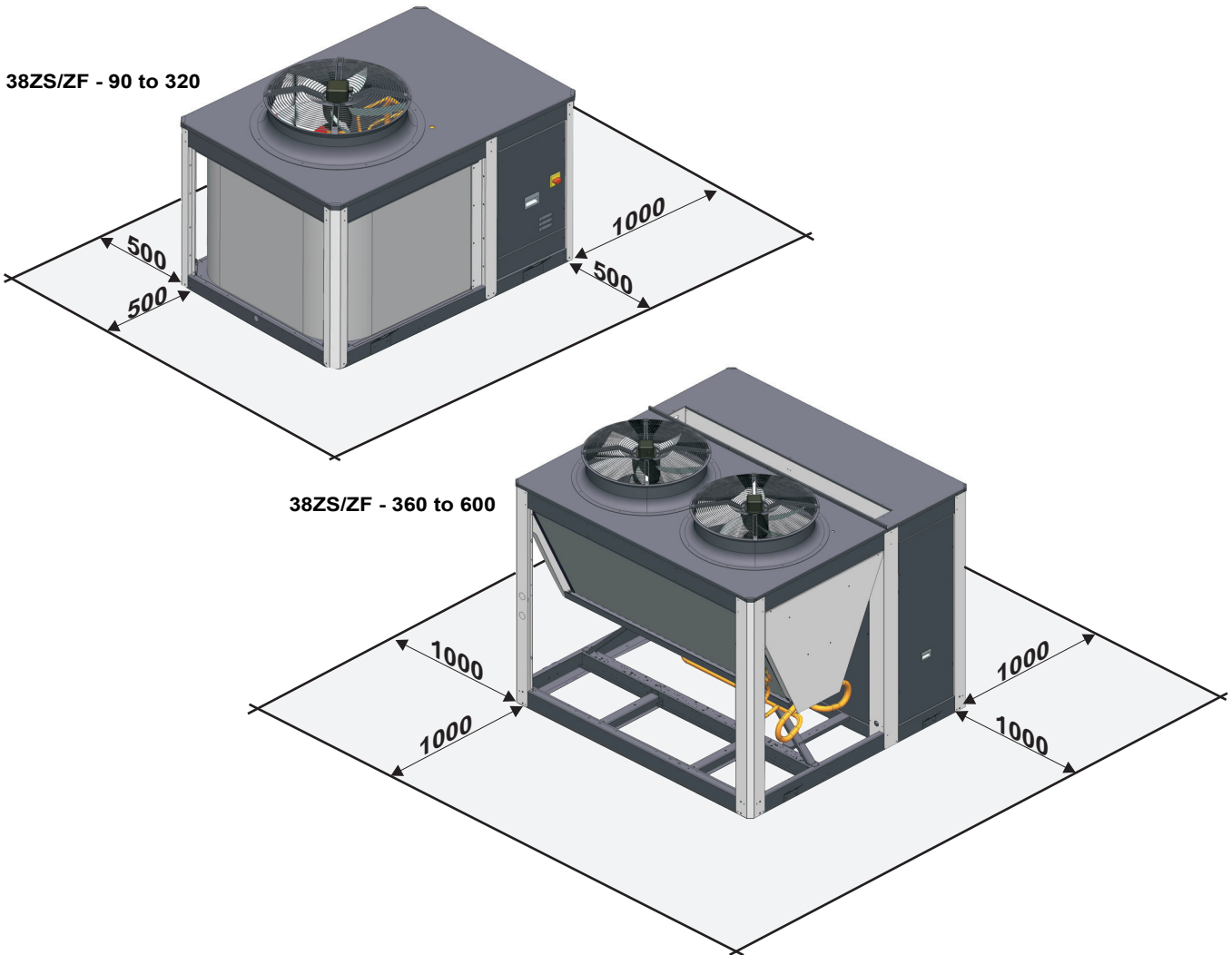

6.4 Sound level

These units are designed to work with a low acoustic level. In any case, the following must be taken into account for the design of the installation: the outdoor environment for acoustic radiation, the type of building for the noise transmitted by air, the solid elements for the transmission of vibrations.

To reduce transmission through solid surfaces to the maximum, it is very advisable to install shock absorbers between the ground or structure and the unit frame. If necessary, a study must be commissioned to an acoustic technician.

Sound power level

38ZS/ZF	90	100	120	160	180	182	200	240	320	360	420	485	540	600
Total dB(A)	74	75	83	80	88	88	88	88	87	89	92	92	92	92

Note: The sound power spectrum can be found in the technical brochure of this series.

Sound pressure level

Measurement conditions: in free field, measured at a distance of 5 metres, directivity 2 and at 1.5 metres from the ground.

38ZS/ZF	90	100	120	160	180	182	200	240	320	360	420	485	540	600
Total dB(A)	48	49	56	54	62	62	62	62	60	62	65	66	66	65

Note: The sound pressure level depends on the installation conditions and, as such, it is only indicated as a guide. Values obtained according to standard ISO 3744.

7 - CHECKING BEFORE COMMISSIONING



Important: Under no circumstance should the unit be started without having read the brochure completely.

7.1 Electrical connection

Installation norms



Important: All connections in the site are the responsibility of the installer. These connections are always made as per the current regulation. Always refer to the wiring diagram provided with the unit.



The installer must provide electrical circuit protections according to the effective legislation.



To prevent electrical shocks, make all electrical connections before energizing the unit. Check that the automatic switch is closed. Omitting this can cause personal damage. Make the ground connection before any other electrical connection.

Power supply

Verify that power supply agrees with the unit name plate and that the voltage remains constant.

Warning: Operation of the unit with an incorrect supply voltage or excessive phase imbalance constitutes misuse which will invalidate the manufacturer's warranty. If the phase imbalance exceeds 2% for voltage, or 10% for current, contact your local electricity supplier at once and ensure that the unit is not switched on until corrective measures have been taken.

Voltage phase imbalance (%)

$$\% \text{ imbalance} = \frac{100 \times \text{max. deviation from average voltage}}{\text{average voltage}}$$

Example:

On a 400 V - 3 ph - 50 Hz power supply, the individual phase voltages were measured with the following values:

AB = 406 V; BC = 399 V; AC = 394 V

Average voltage = $(406+399+394)/3=1199/3 = 399.7$ i.e. 400 V

Calculate the maximum deviation from the 400 V average:

(AB) = $406 - 400 = 6 \rightarrow \% = 100 \times 6 / 400 = 1.5$

(BC) = $400 - 399 = 1 \rightarrow \% = 100 \times 1 / 400 = 0.25$

(CA) = $400 - 394 = 6 \rightarrow \% = 100 \times 6 / 400 = 1.5$

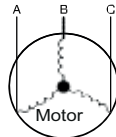

Important: It is the responsibility of the installer to protect the unit from overvoltage coming from the mains or voltage spikes caused by lightning. Depending on the geographic location and the type of mains network (buried or overhead), a lightning rod needs to be installed. Check the local electrical codes and regulations. Failure to comply with the requirements of standards in force in the country of installation will void the warranty.

Wire sizing

To perform the electric installation of the unit (cable glands, wire sizing and their calculations, protections, etc.), refer to the information provided in:

- The technical brochure of this series.

- The name plate data.
- The wiring diagram included with the unit.
- Norms in effect that regulate the installation of air conditioning units and electrical receivers in the country of installation.

Wiring must be selected based on:

- The maximum power input, taking into account all the options it features (refer to the technical brochure and the name plate).
- The distance between the unit and its power source.
- The protection to be placed at the power source.
- Neutral operating conditions.
- The electrical connections (refer to the wiring diagram provided with the unit).
- The temperature the wiring is exposed to;
- The fitting method.

After wire sizing has been completed, the installer must verify the appropriate means of connection and define any modifications necessary on site.

Electronic control

• *CARRIERtc Basic / Medium*

All 38ZS/ZF units have an electronic control: CARRIERtc Basic (models 90 to 182) / CARRIERtc Medium (models 200 to 600) comprised of a control board and a TCO user terminal.

Optionally, this control can have a terminal for pGD1 maintenance that facilitates the initial scheduling of the unit, the modification of the operating parameters and the description of the alarms produced.

Recommendations for the TCO thermostat installation

From the thermostat some of the unit operation aspects are controlled: operation modes, setpoint, differential, timings... Because of this, it is very important to choose an appropriate location within the room since in it is where the unit's control probe is located. This probe must report about the environmental conditions of the occupied area.

The thermostat must be fixed at a height of 1,5 metres from the ground and all possible interferences must be avoided: sun, outdoor air, internal heat sources... Mount the thermostat to the wall using the bracket, do not leave it hanging from the wire or embedding it in the wall.

• *CARRIERtc (optional)*

This control is available for all models and is comprised of an electronic control panel and a pGD1 graphic terminal installed over the unit electric panel and accessed using a polycarbonate collapsible window.

Optionally this terminal can be replaced by a TCO user terminal for installation inside of the premises. In this case the TCO terminal are not allowed to access parameters control and time schedule.

Note: Please refer to these control brochures to obtain more detailed information about its operation.

7 - CHECKING BEFORE COMMISSIONING

Connection chart with electronic control CARRIERtc Basic / CARRIERtc Medium

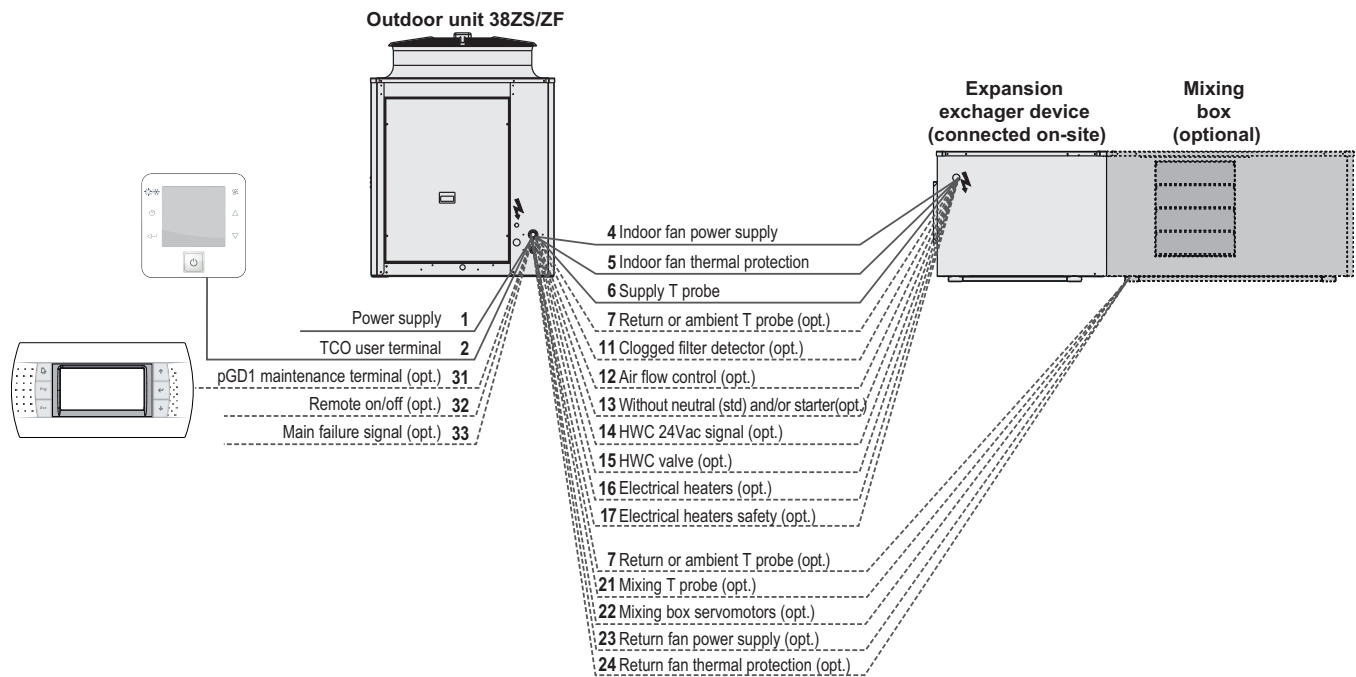

No	38ZS/ZF	90	100	120	160	180	182	200	240	320	360	420	485	540	600
1	Power supply	400 III ($\pm 10\%$)		3 + GND											
2	TCO user terminal connection ①	2 wires for power supply 230V + 1 shielded cable for communication type AGW20 / 22 (1 braided pair + drainwire + shielding)													
4	Indoor fan power supply	3 + GND													
5	Thermal relay signal of the indoor fan	2 wires													
6	Outlet temperature probe	2 wires													
7	Return or ambient temperature probe (optional) ②	2 wires													
11	Clogged filters detector (optional)	2 wires													
12	Air flow control (optional)	2 wires													
13	Unit without neutral (std) and/or soft starter (opt.)	1 wire													
14	HWC 24 Vac signal (optional)	2 wires													
15	HWC valve (optional)	1 wire													
16	Electrical heaters (optional) ③	3 wires (per stage) + GND													
17	Safety thermistors of electrical heaters (optional)	2 wires													
21	Mixing temperature probe (optional) ②	2 wires													
22	Mixing box servomotors power supply (optional) ②	3 wires													
23	Return fan power supply (optional) ②	3 + GND													
24	Thermal relay signal of the return fan (optional) ②	2 wires													
31	pGD1 maintenance terminal connection (optional)	telephone cable 6 wires standard (RJ12 connector)													
32	Remote on/off (optional)	2 wires													
33	Main failure signal (optional)	2 wires													

① If the unit is going to be installed in an industrial environment with a high level of electromagnetic interference, it is recommended to shield the cables of the thermostat control.

② In indoor units with the optional mixing box, these connections are realized directly between the outdoor unit and the terminal board of the box mentioned

③ The power supply for the electrical heater must be protected by an automatic switch and/or fuses to be foreseen by the installer.

7 - CHECKING BEFORE COMMISSIONING

Connection chart with electronic control CARRIERtc (optional)

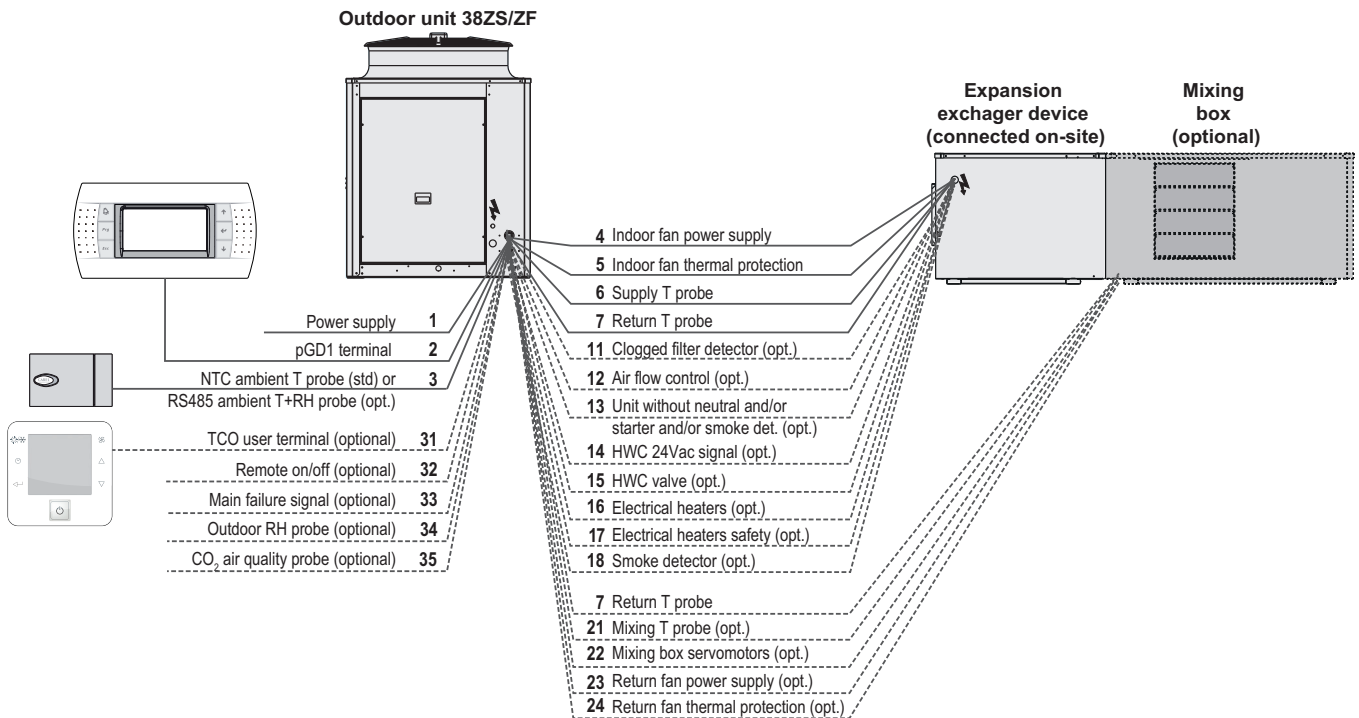

No	38ZS/ZF	90	100	120	160	180	182	200	240	320	360	420	485	540	600
1	Power supply	400 III ($\pm 10\%$)													
2	pGD1 terminal connection														
3	Ambient T probe (std) or RS485 ambient T+RH (opt.)														
4	Indoor fan power supply														
5	Thermal relay signal of the indoor fan														
6	Outlet temperature probe														
7	Return or ambient temperature probe (optional) ②														
11	Clogged filters detector (optional)														
12	Air flow control (optional)														
13	Unit without neutral (std), soft starter and/or smoke detector (opts)														
14	HWC 24 Vac signal (optional)														
15	HWC valve (optional)														
16	Electrical heaters (optional) ③														
17	Safety thermistors of electrical heaters (optional)														
18	Smoke detector (optional)														
21	Mixing temperature probe (optional) ②														
22	Mixing box servomotors power supply (optional) ②														
23	Return fan power supply (optional) ②														
24	Thermal relay signal of the return fan (optional) ②														
31	TCO user terminal connection (optional) ①														
32	Remote on/off (optional)														
33	Main failure signal (optional)														
34	Outdoor RH probe (optional)														
35	CO ₂ air quality probe (optional)														

① If the unit is going to be installed in an industrial environment with a high level of electromagnetic interference, it is recommended to shield the cables of the thermostat control.

② In indoor units with the optional mixing box, these connections are realized directly between the outdoor unit and the terminal board of the box mentioned

③ The power supply for the electrical heater must be protected by an automatic switch and/or fuses to be foreseen by the installer.

7 - CHECKING BEFORE COMMISSIONING

7.2 Cooling connections

Once installed the outdoor and indoor units, the cooling links must be laid between them.

Cooling connections	90	100	120	160	180	182	200	240	320	360	420	485	540	600
Circuit 1: Liquid line	1/2"	1/2"	5/8"	5/8"	5/8"	5/8"	1/2"	5/8"	5/8"	5/8"	5/8"	5/8"	7/8"	7/8"
Circuit 1: Gas line	7/8"	1/8"	1/8"	1/8"	1/8"	1/8"	1/8"	1/8"	1/8"	1/8"	1/8"	1/8"	1/8"	1/8"
Circuit 2: Liquid line	--	--	--	--	--	--	1/2"	5/8"	5/8"	5/8"	5/8"	5/8"	5/8"	7/8"
Circuit 2: Gas line	--	--	--	--	--	--	1/8"	1/8"	1/8"	1/8"	1/8"	1/8"	1/8"	1/8"

The maximum equivalent length of the cooling line is 50 metres, with a maximum geometric height of 40 metres when the outdoor unit is high. For longer distances, up to 100 metres maximum, an oil separator must be used per cooling circuit. If it is the indoor unit which is high, the maximum equivalent length is reduced to 7 metres.

Outdoor unit top

Maximum equivalent length of the cooling line: 50 metres
For longer lengths, up to 100 metres maximum, an oil separator must be used

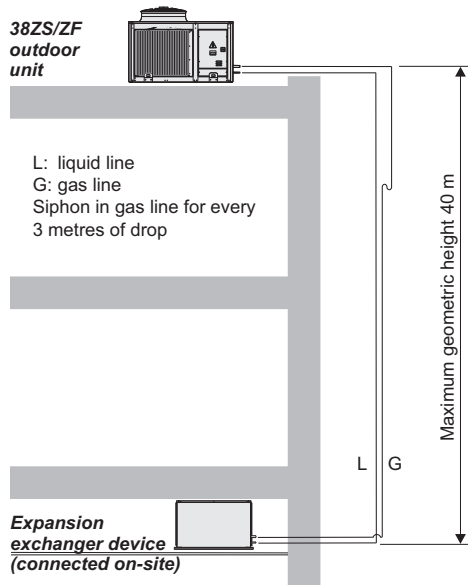

Outdoor unit bottom

Maximum equivalent length of the cooling line: 7 metres

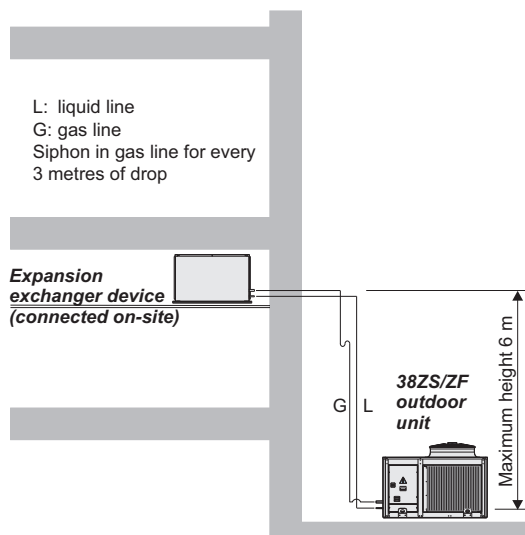

It is recommended to place a siphon in the gas line every 3 metres of shoulder to ease the oil return to the compressor.



For determining the equivalent length, the pressure drops in accessories must be taken into account.

Pressure drops in elbows expressed as equivalent lengths (m):

Tube installation norms must be respected and inspect carefully the tube lay out, looking for the shortest distance and the lowest possible number of curves. Also, chokes must be avoided, using large curve radii (the curve radius must be $\geq 3,5 \times \varnothing$).

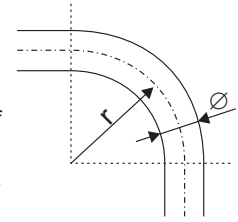

Tube diameter (inches)	1/2"	5/8"	7/8"	1 1/8"
Equivalent elbow length 45° (m)	0,24	0,30	0,39	0,48
Equivalent elbow length 90° (m)	0,45	0,54	0,72	0,90
Equivalent elbow length 180° (m)	0,75	0,80	1,00	1,30

Connection of the unit to the cooling lines

For the refrigerant lines, use only cooling type seamless tubes. Under no circumstance use sanitary type copper pipe.

Following these steps is recommended:

- Revise and clean the tube ends to eliminate the burs from cutting them and any other impurity that could have deposited inside or on the outer surface. How clean the tubes are will dictate the degree of air tightness. Also, we will avoid the dirt formation that may collapse some spots in the cooling circuit.
- Apply isolator to the piping, covering them and affix it with tape. The material used must guarantee the air tightness at operation pressure and temperature.
- Remove the plugs that protect the cooling connections of the unit precisely at the moment of connecting the tubes.
- Align precisely both parts of the connection (unit and piping). There is no error risk when both tubes have different diameters.
- Run a pressure test in the cooling tubes and a search for leaks to verify the cooling installation.
- Create a vacuum in the installation to eliminate humidity inside the circuit.
- Charge the unit with gas as per the data stated in a table of the chapter "Maintenance" and in the unit's data plate. Add the refrigerant slowly via charging valve (schrader type) built into the liquid line of each circuit with compressors stopped, and using the appropriate tools monitoring the pressures to detect if there are any possible anomalies.

Note: Optionally these units can be supplied with service valves and refrigerant load for cooling connections (up to 7,5 meters long).

- If the equivalent length of the cooling lines is over 7 m, an additional charge will be needed per meter as per the following table.

Nominal diameter (")	1/4"	3/8"	1/2"	5/8"	3/4"	7/8"	1"	1 1/8"
Indoor section (cm ²)	0,149	0,444	0,900	1,505	2,282	3,120	4,290	5,346
Liquid line charge (g/m)	19,3	57,0	115,0	193,5	292,3	404,1	550,3	685,7
Gas line charge (g/m)	-	0,2	0,4	0,7	1,0	1,4	2,0	2,5

Note: To ensure that the gas charge is correct, follow the instructions given in chapter "Commissioning".

7 - CHECKING BEFORE COMMISSIONING

7.3 Condensate drain connection

Models 90 to 320 (coil in U)

These units can optionally have an indoor condensate drain pan. The pan has a drain tube of outer diameter of 22 mm to which a PVC or transparent plastic tube must be connected for draining the condensates.

This pan is standard in units with centrifugal fan (optional) (set up a siphon).

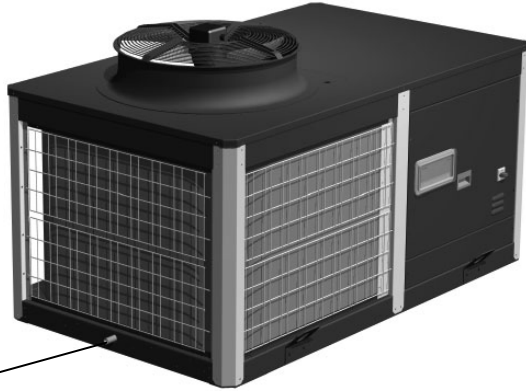

Models 360 to 600 (coil in V)

These units are equipped with two condensates pans located in the lower part of the two coil sides.

These pans drains have a drain tube of outer diameter of 22 mm, to which a PVC or transparent plastic tube must be attached for the condensate draining that reaches the bottom of the unit.

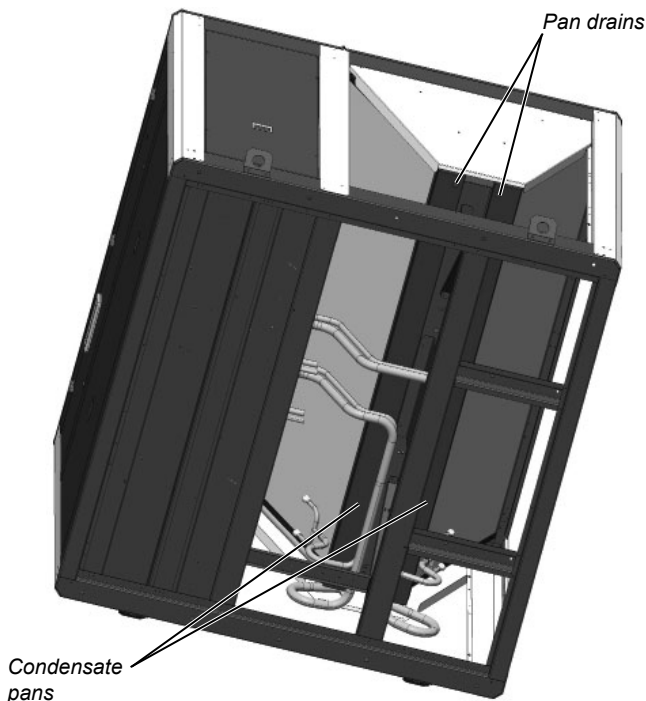

Siphon installation norms

All water drain tubes must be provided with a siphon to avoid bad smell and water spills.

Pan in overpressure:

- It's installed to avoid the access through the drain piping of bad smells.

Pan in underpressure:

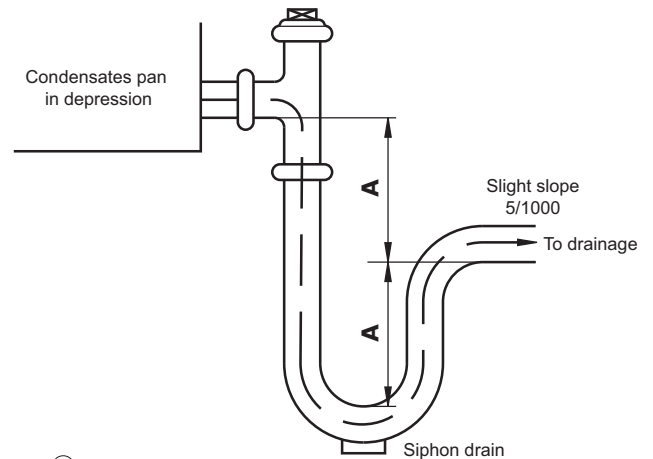

- Besides the above application, water must be suctioned from the pan because of the depression with respect to the motorfan assembly.
- Perform the siphon assembly as per the scheme of the attached starting diagram:
 - For the correct siphon design, the "A" height must be at least twice that of the underpressure (mm.w.c) where the condensate pan is placed.
 - Check that the condensate outlet is not clogged.
 - The drain piping must be slightly sloped to ease circulation towards the drain.
 - The original diameter of the piping must be respected. No reduction can be made.
 - In the case of units installed outdoors, with outdoor temperatures which are lower than 0°C the necessary precautions must be taken to prevent the water in the drain piping from freezing.



Check the watertightness of the connection.

7.4 Checks in the axial fans

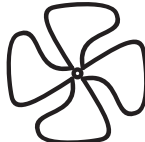
- Before commissioning, check the blade rotation direction and that the axis turns without strokes nor vibrations.
- Once running, check the operation conditions: pressures, flows and consumptions.
- With electronic fans (optional), check that they adapt their rotational speed based on the condensation or evaporation pressure.

WARNING: MUST WEAR SAFETY HELMET. BEFORE OPENING THIS PANEL, SWITCH OFF THE ELECTRIC SUPPLY AND WAIT 2 MIN.

ATTENTION: PORT DU CASQUE OBLIGATOIRE. AVANT L'OUVERTURE DE CE PANNEAU COUPER L'ALIMENTATION ÉLECTRIQUE ET ATTENDRE 2 MIN.

ATENCIÓN: USO OBLIGATORIO DE CASCO. ANTES DE ABRIR LA PUERTA, CORTAR LA ALIMENTACIÓN ELÉCTRICA Y ESPERAR 2 MIN.

2062180

8 - SAFETY ELEMENTS

Low pressure pressostat

When connected to the compressor suction, it will stop its operation when the pressure at that point goes down below the tare value (caused by obstructions in the circuit, excessive dirt in the filters, fan stop or ice formation in the evaporator).



This pressostat disconnects at 2 bar and is automatically reactivated.

High pressure pressostat

Connected to the compressor discharge, it will stop its operation when the pressure at that point reaches the setpoint. It disconnects at 42 bar and it is automatically reactivated.

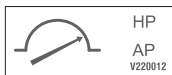

Safeties at the compressor

The scroll type compressor that these units as standard have the following safeties:

- Non-return valve built into the compressor.
- Temperature probe for the discharge from the compressor to protect the unit with discharge temperatures greater than 135°C.

Main door switch

By using a mechanical device, it impedes access to the electric panel when the unit is with voltage.

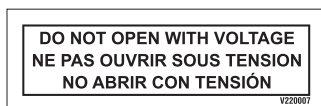

Magnetothermals for line protection

They are located at the beginning of the power lines for the compressors and motor fan(s) to protect them.

Automatic switch in the control circuit

Magnetothermal switch that protects the operation circuit against continuous surges as well as against high currents of short duration (short circuits).

Defrost control

This safety device is intended to eliminate ice which could accumulate in the outdoor coil when the unit is working in the heating cycle. Defrosting is carried out by the control depending on the value measured by the sensor(s) on the outdoor coil(s) and the time set between defrosting operations.

Condensation and evaporation pressure control

This safety device, integrated in the control, enables managing the outdoor fan(s) when the units are working in cooling mode with low outdoor temperatures (condensation control) or in heating mode with high outdoor temperatures (evaporation control). This aids the unit's operation in all the seasons.

In the case of EC electronic fans (optional), speed control will be proportional based on the average pressure measured by the pressure transducer(s) in the outdoor coil(s).

Protection of the electric panel (optional)

Electrical heater for protecting the components of the electric panel.

Anti-fire safety

With the optional return air probe, the electronic control can activate an anti-fire safety device that detains the unit when the return air surpasses a temperature of 60°C (by default). It cannot return to operation until the temperature has dropped to below 40°C.

9 - COMMISSIONING

9.1 Checks prior to commissioning

- It is advisable to make a complete sketch of the installation including the location of the unit and all the components used. This will be very helpful for maintenance and repairs to the installation.
- The following must be verified:
 - That the electrical power supply remains constant and that it corresponds to that featured on the unit data plate.
 - That the electric installation has been carried out according to the electric wiring diagram provided with the unit (consult the chapter on "Electrical connection").
 - The correct connection of the sensors supplied with the unit (consult the chapter on "Electrical connection").
 - That there are no cables close to heat sources.
- Once the above verifications have been carried out, the control circuit is supplied with voltage by the automatic control switch.

Attention: the compressor crankcase heater must be put under voltage for 24 hours before starting the compressor.

WICHTIG: WIEDERBEHEIZUNG DER OLWANNE

BEIDER ERSTEN INBETRIEBSETRUNZ ODER NACH EINER LANGEN STROMUNTER-BRECHUNG BRINGEN SIE DIE MASCHINE UNTER SPANNUNG 24 STRUNDERLANG BEVOR SIE DEN(DIE) KOMPRESSOR(EN) EINSCHALTEN KOENNEN.

IMPORTANT: CRANKCASE HEATING

FOR THE FIRSTSTART OR AFTER A LONG TIME OUT OF VOLTAGE PUT THE MACHINE ON LIVE 24 HOURS BEFORE TO ALLOW THE COMPRESSOR(S) STARTING

IMPORTANT: SURCHAUFFE CARTER D'HUILE

AU PREMIER DÉMARRAGE OU APRÈS UNE ABSCENCE DE COURANT PROLONGÉE, METTRE LA MACHINE SOUS TENSION 24 HEURES AVANT D'AUTORISER LE DÉMARRAGE DU(DES) COMPRESSEUR(S).

IMPORTANTE: RISCALDARE IL CARTER DELL'OLIO

AL PRIMO AVVIAMENTO U DOPO UNA INTERRUZIONE PROLUNGATA DELLA ALIMENTAZIONE ELETTRICA, LASCIARE LA MACCHINA SOTTO TENSIONE PER 24 ORE PRIMA DI AUTORIZZARE L'AVVIAMENTO DEL(DEI) COMPRESORE(I).

IMPORTANTE: RECALENTAMIENTO DE ACEITE DEL CÁRTER

ANTES DEL PRIMER ARRANQUE O DESPUÉS DE UNA AUSENCIA DE CORRIENTE POR UN LARGO PERIODO DE TIEMPO, CONVIENE QUE LA UNIDAD ESTÉ CONECTADA UN MÍNIMO DE 24 HORAS.

V220084

- All the 38ZS/ZF units are equipped with scroll type compressors and a phase control relay. Verify that they rotate in the correct sense and, if not, reverse the power wires.

SCROLL COMPRESSOR.
CHECK SENSE OF ROTATION
COMPRESSEUR SCROLL.
VÉRIFIER LE SENS DE ROTATION
COMPRESOR SCROLL.
COMPROBAR SENTIDO DE GIRO

V220040

Control of the refrigerant charge

Note: it is necessary charge of refrigerant following the recommendations given in the section "Cooling connections".

R 410A

- To make sure that the unit is filled with the correct charge of refrigerant, check the values of overheating and subcooling, circuit by circuit, with the system running at full capacity.
- If the refrigerant charge is lower than required, the suction pressure will drop and overheating on the compressor inlets will be high. This can cause an interruption in operation due to activation of the refrigerant charge safety device.
- If the refrigerant load is insufficient the liquid sight glass will not be clean, gas bubbles will appear as foam.

The liquid sight glass can be accessed via the electric panel (in models 38ZS/ZF - 90 to 320) or through the cooling circuit since it is located in the actual pipe (in models 38ZS/ZF - 360 to 600).

- To adjust the refrigerant charge, a schrader type valve is built into the unit on the liquid line for each circuit.

Models 38ZS/ZF 90 to 320 (coil in U)

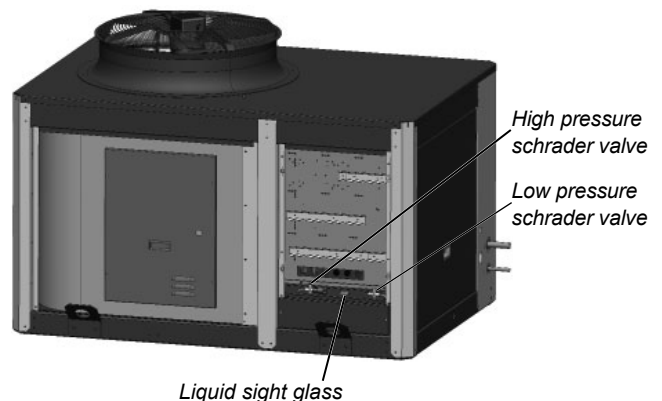

Models 38ZS/ZF 360 to 600 (coils in V)

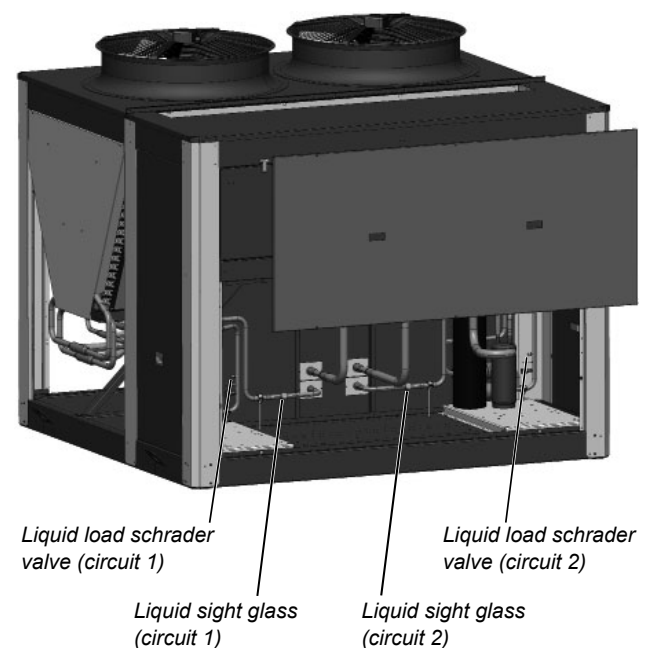

9 - COMMISSIONING

- Verify the absence of any leaks of the refrigerant. In case of a leak:
 - Completely drain the refrigerant charge using a specific recovery machine for R-410A and repair the leak.
 - Next, reload the refrigerant into the unit according to charge data provided in a table of the chapter on "Maintenance" and in the unit's data plate.
 - Add the refrigerant via the charging valve using the appropriate equipment and tools, with the compressors stopped, monitoring the pressures to control any anomaly.

9.2 Possible problems at commissioning

All indications given in this manual must be respected and complied with to guarantee a correct operation of the units.

Next, several possible operation problems are stated which could happen if the conditions of the commissioning are not appropriate.

- Air flow lack: very high differences between inlet and outlet temperatures, originated by a high pressure drop in the ducts, or by other causes that impede the correct circulation.
- Air recirculation in the unit, originated by some obstacle in the air aspiration or outlet.
- Noise problems because of excessive air flow in the grille.
- Water overflowing to the pan problems, originated by an excessive flow, an incorrect siphon installation or because a defective unit level.
- Refrigerant circuit humidity problem, because of an incorrect vacuum realization.

9.3 Operational checks

Check the unit operation by verifying the electronic control and the safety devices.

It is also recommendable to create a report, taking note of the date, which includes the following information:

- the nominal voltage,
- current absorbed by the compressors, fans and other electrical components,
- significant temperatures in the cooling circuit (see attached table),
- other aspects considered interesting such as alarms detected by the electronic control of the unit.

The recording of these parameters whilst the unit is running allows controlling the installation performance and it is the best possible way to avoid breakdowns since the analysis of these data makes early detection of anomalies possible or the provision of the necessary means available to ensure that they do not take place.

Operating readings

Cooling MODE		
Compressor	Suction pressure	bar
	Suction temperature (1)	°C
	Condensation pressure	bar
	Condensation temperature (2)	°C
Air condenser	Gas inlet temperature	°C
	Liquid outlet temperature (3)	°C
	Air inlet temperature	°C
	Outdoor temperature	°C
	Air outlet temperature	°C
Air evaporator	Air inlet temperature	°C
	Air outlet temperature	°C
	Liquid inlet temperature	°C
	Evaporation outlet temperature (4)	°C
Subcooling (2) - (3)		°C
Overheating (4) - (1)		°C

Heating MODE		
Compressor	Suction pressure	bar
	Suction temperature (1)	°C
	Condensation pressure	bar
	Condensation temperature (2)	°C
Air evaporator	Liquid inlet temperature	°C
	Gas outlet temperature (4)	°C
	Air inlet temperature	°C
	Outdoor temperature	°C
	Air outlet temperature	°C
Air condenser	Air inlet temperature	°C
	Air outlet temperature	°C
	Gas inlet temperature	°C
	Liquid outlet temperature (3)	°C
Subcooling (2) - (3)		°C
Overheating (4) - (1)		°C

10 - MAINTENANCE

The minimal maintenance operations and their periodicity will be made in accordance with national regulations.

All work on the unit's electrical or refrigerant systems must be carried out by a qualified authorised technician. See the standard EN 378-4.

It is advisable to sign a maintenance contract with the installer or an approved maintenance company.

10.1 General recommendations

Safety instructions

- Technicians working on the unit must wear the necessary safety gear (e.g. gloves, eye protection, insulating clothing, safety shoes).
- Similarly, it is recommended that personnel working close to sources of high noise emission wear ear defenders. The ear defenders should in no way impede the wearing of other protective equipment.
- The surfaces of the compressor and pipes may reach temperatures of over 100°C and cause burns if touched. Likewise, the surfaces of the compressor may in some cases drop to freezing temperatures which can cause frostbite. It is therefore important to take special care when carrying out maintenance work.
- Do not climb on the machine; use a platform to work at the necessary height.
- Do not climb on the copper refrigerant pipes.



Caution: Do not work on any electrical components without first turning off the main door switch in the electric cabinet.

Preliminary advise

- Keep the unit clean.
- To avoid accidents and ensure proper ventilation of the coil, keep the unit and the space around it clean and clear of clutter.
- Check the fouling level of the coil.

Oil

Oils for refrigeration units do not pose any health risks if they are used in compliance with the precautions for use:

- Avoid unnecessary handling of components lubricated with oil. Use protective creams.
- Oils are flammable and must be stored and handled with care. Disposable rags or cloths used in cleaning must be kept away from open flames and disposed of in the appropriate manner.
- Containers must be stored with their caps on. Avoid using oil from an opened container stored under incorrect conditions.

- Check the oil level and aspect. In case of a colour change, check the oil quality using a contamination test.
- In the case of the presence of acid, water or metallic particles, replace the affected circuit oil, as well as the filter dryer.
- If all the oil must be emptied, replace it imperatively with new oil of the same grade as the original oil which has been stored in a hermetically sealed container until its time of use.

The oil type recommended for these units is:

Copeland 3MAF 32cST, Danfoss POE 160SZ, ICI Emkarate RL 32CF, Mobil EAL Artic 22CC.

The following table indicates the required volume:

38ZS/ZF	90	100	120	160	180	182	200
Volume (l)	3,0	3,3	3,3	3,3	6,2	6,2	2 x 3,3

38ZS/ZF	240	320	360	420	485	540	600
Volume (l)	2 x 3,3	2 x 3,3	2 x 6,2	2 x 6,2	2 x 6,2	2 x 6,2	2 x 6,2

Oil separator (optional)

When the maximum equivalent length of the cooling line is greater than 50 metres, an oil separator must be fitted.

- During the first few days of operation check the oil level in the compressor sight glass. If there is not enough, oil can be added (via the compressor schrader valve or the unit low pressure).

Refrigerant

Only qualified personnel must perform a periodic leak testing, in accordance with the regulation (EC) **No. 517/2014**.

- The frequency of checks is no longer related to the refrigerant charge but to its global warming potential:

$$\text{Charge kg x GWP} = \text{t CO}_2\text{e}$$

Carbon dioxide equivalency (t CO₂e) is a quantity that describes, for a given mixture and amount of greenhouse gas, the amount in tonnes of CO₂ that would have the same global warming potential (GWP).

The number of tonnes of CO₂ equivalent (t CO₂e) can be consulted in the following table:

38ZS/ZF	90	100	120	160	180	182	200
Charge (kg)	6,3	6,4	8,6	8,2	9,2	12,8	17,3
Environ. impact (t CO ₂ e)	13,2	13,4	18,0	17,1	19,2	26,7	36,1

38ZS/ZF	240	320	360	420	485	540	600
Charge (kg)	17,4	22,2	22,7	31,4	31,4	33,4	33,6
Environ. impact (t CO ₂ e)	36,3	46,4	47,4	65,6	65,6	69,7	70,2

10 - MAINTENANCE

- Operators shall ensure that the unit is checked for leaks and minima according to the following frequency:
 - t CO₂e < 5 not subjected
 - t CO₂e 5 to 50 ... every year
 - t CO₂e 50 to 500 every 6 months
 - t CO₂e > 500 every 3 months
- Where a leakage detection system has been installed the frequency of checks is halved.

Note: These machines use R410A. It is essential that technicians use equipment which is compatible with R410A with a working pressure which is approximately 1.5 times higher than that of units using R407C.

- Always remember that refrigeration systems contain pressurised liquids and vapours. All necessary provisions must be made when the system is partially opened: ensure the part of the circuit concerned is not pressurised.
- Partial opening of the primary refrigerating circuit will cause a certain quantity of refrigerant to be released into the atmosphere. It is essential to keep the amount of lost refrigerant as low as possible by pumping the charge and isolating it in another part of the system.
- The refrigerant and lubricating oil, and the low-temperature liquid refrigerant in particular, may cause inflammatory lesions similar to burns if they come into contact with the skin or eyes. Always wear protective eyewear, gloves and other protective equipment when opening pipes or tanks liable to have liquids in them.
- Store unused refrigerant in the appropriate containers and limit the amounts stored in mechanical rooms.
- Cylinders and tanks of refrigerant must be handled with care and signs warning users of the related poisoning, fire and explosion hazards must be clearly visible.

Refrigerant that reaches the end of its life must be collected and recycled in accordance with applicable regulations.

10.2 Servicing

It's recommended to note down the operating readings and perform the following checks at least twice a year and mandatory after each time a unit is started for seasonal use.

Weekly checks

With the unit running at full capacity, check the following values:

- LP compressor suction pressure and HP compressor discharge pressure.
- The oil level and its appearance. If the colour changes, check the quality.
- Also check whether the safety devices operate correctly.
- Check the entire system for traces of water or oil under or around the unit and for any unusual noises.

Monthly checks

- Check all the values listed in the table "Operating readings"

on chapter 9.

- Check for corrosion on all metal surfaces (chassis, casing, exchangers, electric cabinet, etc.).
- Make sure that the insulating foam is neither detached nor torn.
- Check the coolants for any impurities which could cause wear or corrosion in the exchanger.
- Check the circuits for leaks.
- Check whether the safety devices and the expansion valve(s) operate correctly.

Annual checks

- Carry out the same inspections as during the monthly checks.
- Carry out an oil contamination test (every year or every 5000 hours). If acid, water or metal particles are found, replace the oil in the circuit concerned and the dryer. Follow the recommendations of paragraph 10.1.
- Check the electrical connections to ensure they are tight and in good condition.
- Check the condition of the contacts and the current at full load on all three phases.
- Check the electrical box for water seepage.

N.b.: The intervals for cleaning are given as a guide and should be adapted to each unit.

10.3 Access to the main components

Next, some recommendations are stated to perform the cleaning of the unit's components:

Compressor

In the case of compressor replacement:

- Disconnect the unit from power supply.
- Completely empty the refrigerant charge using a specific recovery unit for R-410A
- Disconnect electrically the compressor.
- Carefully unsolder the suction and discharge piping.
- The compressor is fixed onto the platform with 4 screws.
- Unscrew the fixings.
- Place the new compressor and check that it has a sufficient oil charge.

Warning: when tightening the compressor screws, please consult the maximum torque that can be applied.

If a torque wrench is not available, tighten them until they are snug then tighten a further ¼ turn.
- Solder the suction and discharge piping.
- Connect the compressor in accordance with the wiring diagram.

- Make vacuum and next, reload the gas into the unit according to charge data provided in the table of "General recommendations" and in the unit's data plate.

10 - MAINTENANCE

Dryer filter

- The filter function is to preserve the cooling circuit clean and without humidity, neutralizing the acids that can be found in the cooling circuit.
- Measure the difference in the temperature of the pipes at the dryer inlet and outlet.
- If necessary, replace.

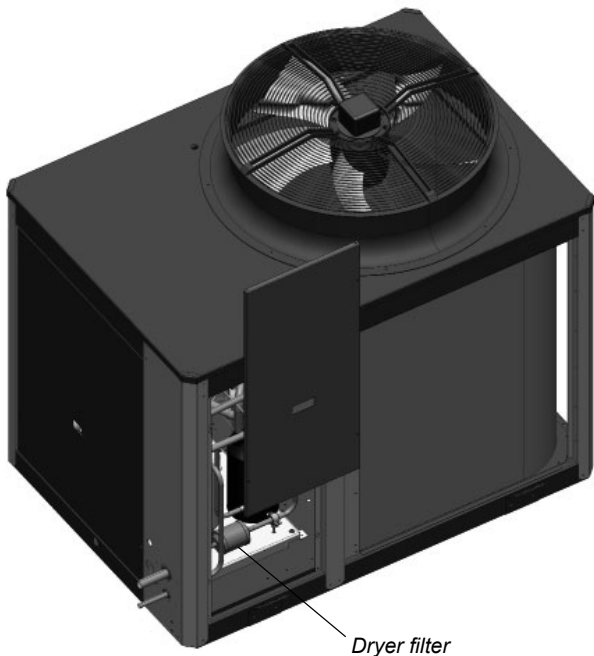

Liquid sight glass

- This sight glass, located on the liquid line, after the dehydrating filter, enables controlling the refrigerant load and the presence of moisture in the circuit. The presence of bubbles in the indicator means that the refrigerant fluid load is insufficient or that there are non-condensable products in the cooling circuit. The presence of moisture is characterised by the change in colour of the control paper located on the sight glass.
- In the 38ZS/ZF units the liquid sight glass is accessed via the access panel to the electric panel (models 90 to 320) or via the cooling circuit access (models 360 to 600)..

Warning:

If the unit stops, certain indicators may appear in yellow; the change in colour is due to the sensitivity, which depends on the temperature of the fluid.

These will change to green after a few hours of the unit operating.

If the indicators remain yellow, that will indicate the presence of excessive humidity in the circuit. This will require the presence of a specialist.

Condensate drain pan

- Check that the condensate pan is clean. There should be no stagnant water.
- Check that the drain is not clogged.
- Cleaning of the pan can be done with water and non-abrasive detergent.

Note: in the section "Condensate drain connection" are images with the position of the drain for all units.

Air coil

- Check that the coil is free from dust and grease.
- Cleaning the accumulated dust on the coil can be performed with a vacuum cleaner perpendicular to the fins or with a low-pressure water cleaner. Grease can be removed with water with degreaser. Do not put stress on the fins as they could deform.

Note: models 38ZS/ZF - 90 to 320 with coil in U may incorporate a protection grille for the coil (optional). This grille is fixed by modules in the holes made for this goal in the unit's support. Remove the grille to clean the coil.

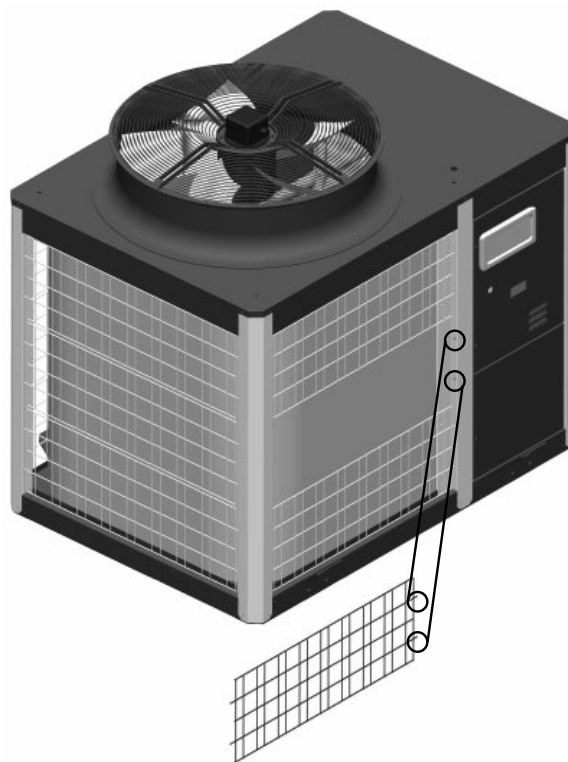

Use safety gloves for this task. Take care with the sharp parts of the coil.

11 - CONTROL AND ANALYSIS OF BREAKDOWNS

Symptom	Cause	Solution
Evaporation pressure very high in relation with the air inlet	<ul style="list-style-type: none"> a) Charge excess b) High air temperature c) Compressor suction not air tight d) Cycle reversing valve in middle position 	<ul style="list-style-type: none"> a) Collect refrigerant b) Verify overheating c) Verify compressor state and replace d) Check that the valve is not clogged. Replace if necessary
Very low condensation pressure	<ul style="list-style-type: none"> a) Gas lack b) Compressor suction not air tight c) Cycle reversing valve in middle position d) Liquid circuit plugging 	<ul style="list-style-type: none"> a) Search for leaks, complete charge b) Verify compressor state and replace c) Check that the valve is not clogged. Replace if necessary d) Verify the dehydrating filter and expansion valve
Condensation pressure very high in relation to the air outlet, high pressostat cutoff	<ul style="list-style-type: none"> a) Insufficient air flow b) Air inlet temperature very high c) Dirty condenser (does not exchange) d) Much refrigerant charge (flooded condenser) e) The condenser fan is broken down f) Air in the cooling circuit 	<ul style="list-style-type: none"> a) Verify the air circuits (flow, filter cleanliness...) b) Verify the control thermostat readjustment c) Clean it d) Collect refrigerant e) Repair f) Make vacuum and charge
Evaporation pressure too low (low pressure safety cut-off)	<ul style="list-style-type: none"> a) Low flow in evaporator. Air recirculation b) Frozen evaporator c) Liquid line as different temperatures at filter inlet and outlet d) Gas lack e) Very low condensation pressure f) Evaporator fan broken down 	<ul style="list-style-type: none"> a) Verify the air circuits (flow, filter cleanliness...) b) Verify defrost c) Replace filter d) Search for leaks, complete charge e) Temperature of air or water in condenser very low (air or water flow very high), adjust flow f) Repair
Compressor does not start, does not make noise (humming)	<ul style="list-style-type: none"> a) No power b) The contacts of a control element are open c) Timing of anti cycle short does not allow the starting d) Open contact e) Contactor coil burnt f) Indoor klixon open 	<ul style="list-style-type: none"> a) Check differential, fuses b) Verify the safety chain of the electronic control c) Verify electronic control d) Replace e) Replace f) Wait for reactivation, verify current absorbed
Compressor does not start, motor sounds intermittently	<ul style="list-style-type: none"> a) Electrical power supply very low b) Power cable disconnected 	<ul style="list-style-type: none"> a) Control line voltage and locate voltage drop b) Verify connections
Repeated compressor starts and stops	<ul style="list-style-type: none"> a) Because of high pressure b) Control differential too short (short cycle) c) Insufficient gas, cut-off because of low pressure d) Dirty or frosted evaporator e) The evaporator fan does not work, cuts off the low pressostat f) Expansion valve damaged or clogged by impurities (cuts off the low pressure safety) g) Dehydrating filter clogged (cuts off the low pressure safety) 	<ul style="list-style-type: none"> a) Verify charge b) Increase differential c) Search for leak, reload unit d) Clean, verify evaporator air circuit e) Replace or repair f) Replace, as well as filter g) Replace
The compressor makes a noise	<ul style="list-style-type: none"> a) Loose attachment b) Oil lack c) Compressor noise 	<ul style="list-style-type: none"> a) Fix b) Add oil to recommended level c) Replace
Noisy operation	<ul style="list-style-type: none"> a) Unit installed without antivibration protection 	<ul style="list-style-type: none"> a) Place base over shock absorbers
Cycle reversing is not carried out: - No defrosting - Does not change winter - summer cycles	<ul style="list-style-type: none"> a) Electrical fault b) Inversion valve coil defective c) Defrost method not working d) Cycle reversing valve in middle position e) Control fault 	<ul style="list-style-type: none"> a) Locate and repair b) Replace c) Verify parameters d) Tap with running compressor. Replace if necessary e) Locate and repair
Alarm or reading error in the humidity probe (with enthalpic control)	<ul style="list-style-type: none"> a) Dirt in the humidity sensor 	<ul style="list-style-type: none"> a) Disassembly the probe encapsule. Proceed to clean the sensor with some soft cotton element and non-abrasive fluid, without pressing it. Reassemble the casing, checking that the cable is in contact externally with the metallic mesh.

12 - FINAL SHUTDOWN

12.1 Shutting down

Separate the units from their energy sources, allow them to cool then drain them completely.

12.2 Recommendations for disassembly

Use the original lifting equipment.

Sort the components according to their material for recycling or disposal, in accordance with regulations in force.

Check whether any part of the unit can be recycled for another purpose

12.3 Fluids to be recovered for treatment

- Refrigerant
- Energy transfer fluid: depending on the installation, water, glycol/water mix.
- Compressor oil

12.4 Materials to be recovered for recycling

- Steel
- Copper
- Aluminium
- Plastics
- Polyurethane foam (insulation)

12.5 Waste electrical and electronic equipment (WEEE)

At the end of its life, this equipment must be disassembled and contaminated fluids removed by professionals and processed via approved channels for electrical and electronic equipment (WEEE).



Important: In order to recycle these units follow the stipulations of Directive 2012/19/EU on *Waste electrical and electronic equipment* (WEEE).



Order No.: 10257, 07.2019. Supersedes order No.: 11.2017
Manufacturer reserves the right to change any product specifications without notice.



ISO-9001



Manufactured for CARRIER in Spain.
Printed in the European Union.